

INSTRUCTION MANUAL

GPS RECEIVER UNIT

HHGP1

TOSHIBA CORPORATION

© TOSHIBA Corporation 2001
All Rights Reserved.

(Ver. 1.6)



Safety Precautions

Before using this product, please read this chapter carefully.

This chapter describes the safety precautions recommended when using the GPS receiver unit type HHGP1. Before installing and using the equipment, this chapter must be thoroughly read and understood.

Explanation of symbols used

Signal words such as DANGER, WARNING, and two kinds of CAUTION, will be followed by important safety information that must be carefully reviewed.

 DANGER	Indicates an imminently hazardous situation which will result in death or serious injury if you do not follow the instructions.
 WARNING	Indicates a potentially hazardous situation which could result in death or serious injury if you do not follow the instructions.
 CAUTION	Indicates a potentially hazardous situation which if not avoided, may result in minor injury or moderate injury.
CAUTION	Indicates a potentially hazardous situation which if not avoided, may result in property damage.

⚠ DANGER

- **Installing arrester**

Install a surge arrester between the antenna and the GPS receiver and ground it in accordance with the guidelines in this manual. Otherwise, it may cause electric shocks, injury or malfunction.

⚠ WARNING

- **Exposed terminals**

Do not touch the terminals of this equipment while the power is on, as the high voltage generated is dangerous.

- **Residual voltage**

Hazardous voltage can be present in the DC circuit just after switching off the DC power supply. It takes approximately 30 seconds for the voltage to discharge.

- **Fibre optic**

When connecting this equipment via an optical fibre, do not look directly at the optical signal.

⚠ CAUTION

- **Earth**

The earthing terminal of the equipment must be securely earthed.

CAUTION

- **Operating environment**

The equipment must only be used within the range of ambient temperature, humidity and dust detailed in the specification and in an environment free of abnormal vibration.

- **Ratings**

Before applying the DC power supply to the equipment, check that they conform to the equipment ratings.

- **Connection cable**

Carefully handle the connection cable without applying excessive force.

- **Modification**

Do not modify this equipment, as this may cause the equipment to malfunction.

- **Disposal**

When disposing of this equipment, do so in a safe manner according to local regulations.

Contents

Safety Precautions	1
1. Introduction	5
2. Characteristics	5
3. Configuration	6
3.1 Configuration of GPS Receiver Unit	6
3.2 Outline of GPS Receiver Unit and Function	7
4. Handling	8
4.1 Setting the GPS Receiver Unit	8
4.2 How to Turn on the Power	9
4.3 Checking the 1PPS Signal	9
5. Operation	10
5.1 1PPS Signal Output	10
5.2 Time Data Output	11
6. Installation	12
6.1 Receipt of GPS Receiver Unit	12
6.2 Installing GPS Receiver Unit	12
6.3 Installing Antenna	12
6.4 Installing Surge Arrester	15
6.5 Installing Fibre Optics	15
6.6 Connecting the Power Supply and the Earthing Terminal	16
7. Preparation for Installation	17
7.1 Selecting an Antenna and Cables	17
7.2 Selecting Coaxial Cables and Conversion Adapters	17
7.3 Selecting an Antenna Installation Location	18
8. Maintenance	19
8.1 Regular Maintenance	19
8.2 Troubleshooting	19

Appendix A Outline of GPS Receiver Unit	21
Appendix B Technical Data	23
Appendix C Specification of Recommended Antenna and Arrester	27
Appendix D Supplement	31

■ The data given in this manual are subject to change without notice. (Ver. 1.6)

1. Introduction

The GPS (Global Positioning System) receiver unit is a device that receives the information from satellites and outputs time signals synchronous to UTC (Universal Coordinated Time) to external devices. The GPS receiver unit provides multiple outputs with optical signals for noise immunity.

2. Characteristics

■ Highly accurate time signal output

Realizes a precision with respect to $\pm 2\mu\text{s}$ for UTC (UTC: Universal Coordinated Time) (excluding the propagation delay time on the cable).

■ Reduced cabling work

Adopting the signal superimposition method, the unit can be connected to an external device with a single optical fibre only.

■ Application to a large system

Equipped with eight ports for output, the time distribution can be made to multiple devices separated from each other by a maximum of 1 km.

■ High reliability

Aimed at reducing the number of parts through high-integration circuits and high-density mounting technology, thus securing high reliability.

3. Configuration

3.1 Configuration of GPS Receiver Unit

Figure 3.1.1 shows the configuration of the GPS receiver unit.

The GPS receiver unit receives electromagnetic signals from satellites through an antenna and outputs time data to external devices. Through an internal receiver, the unit generates serial time data and 1-second pulses (1PPS signals), based on the received electromagnetic signal. Each 1PPS signal occurs at the instant in time given by its accompanying frame of serial data.

To reduce the number of cables to external devices, time data and 1PPS signals are superimposed through a mixing circuit before being output to the optical fibre.

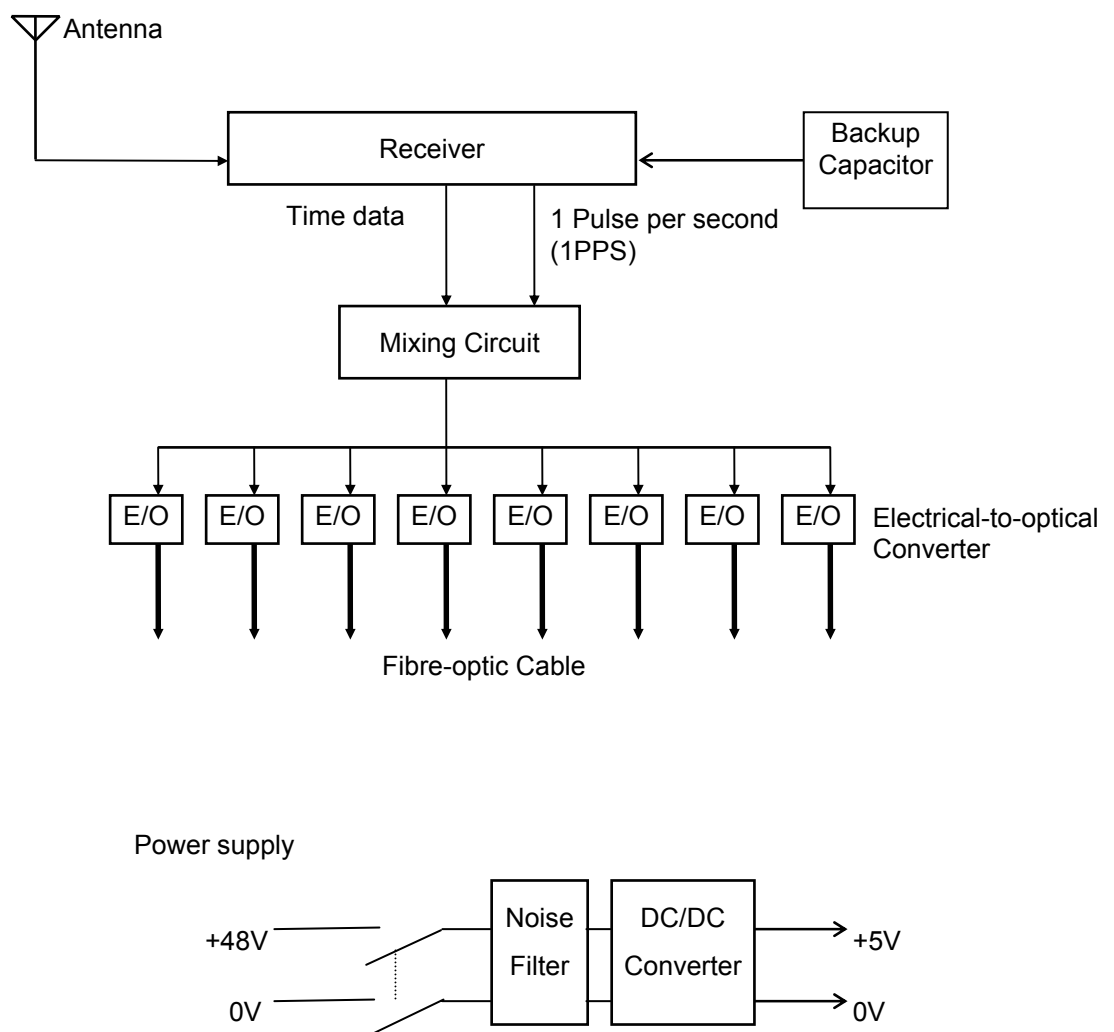
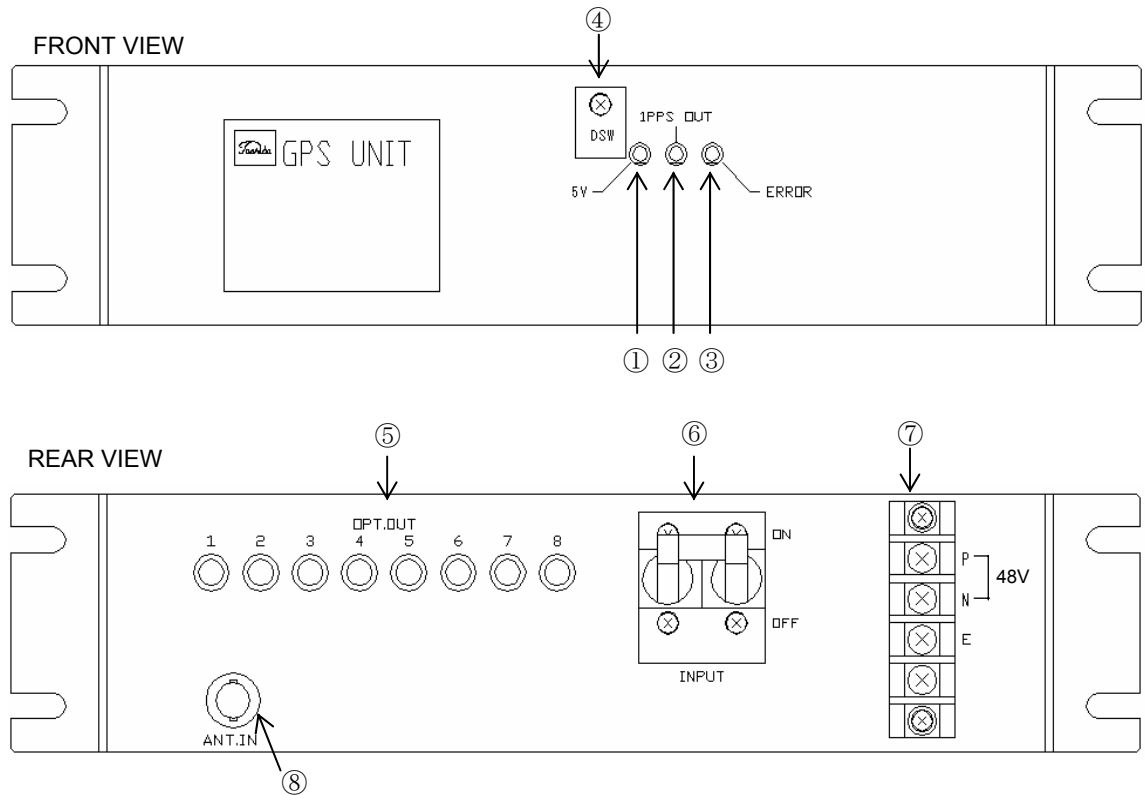

Figure 3.1.1 Configuration of GPS Receiver Unit

3.2 Outline of GPS Receiver Unit and Function

Figure 3.2.1 shows outline and functions of GPS receiver unit.



No.	Device	Indication	Functions
①	Yellow LED	5 V	Turns on when the power (5Vdc) is supplied.
②	Yellow LED	1PPS OUT	Blinks when 1PPS signals are output synchronously with UTC.
③	Red LED	ERROR	Turns on when the internal crystal oscillator stops.
④	DIP switches	DSW	Set the GPS receiver unit settings. During operation, these DIP switches are covered to prevent erroneous operations.
⑤	Signal output ports	OPT.OUT	Outputs time signals. The optical fibre is connected here.
⑥	Power supply switch	INPUT	Turns on or off the power of the GPS receiver unit.
⑦	Terminal block	—	The 48V dc power is applied and the earth cable is connected. P: 48Vdc, N: 0Vdc, E: earth
⑧	Antenna terminal	ANT.IN	The antenna cable is connected.

Figure 3.2.1 Outline and Functions of GPS Receiver Unit

4. Handling

4.1 Setting the GPS Receiver Unit

The GPS receiver unit is set in accordance with the requirements of the system by using the DIP switches located on the front panel of the unit.

To prevent erroneous operations, the DIP switches are protected with a cover. As shown in Figure 4.1.1, when the cover is rotated after loosening the cover screw with a screwdriver, the switches are exposed thus making it possible to handle them. Switches are handled with a sharp-pointed object such as a screwdriver and set to “ON” or “OFF” by pushing them up or down respectively. After accessing the switches, tighten the cover screw to its original state.

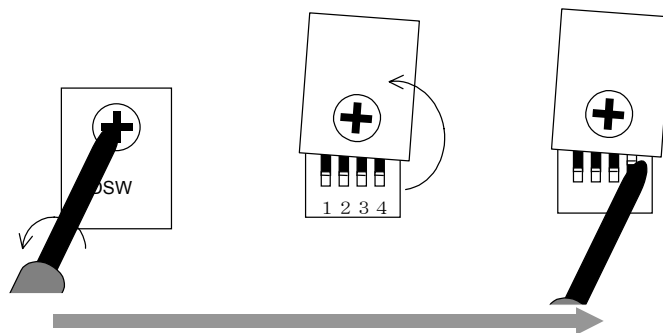

Figure 4.1.1 Switch Operation Method

Four switches are numbered 1 to 4 from left to right. (The numbers are indicated on their respective switches.)

Table 4.1 shows the function and setting of each switch. (All the switches are set to “OFF” for default setting.)

Table 4.1 Setting the Switches

Switch No.	Function	Setting	
		ON	OFF (default)
1	Location mode change	Location fixing mode	Location estimation mode
2	Reliability/TRAIM mode change	Normal/TRAIM OFF	High-reliability/TRAIM ON
3	Optical level test	Continuous light emission	Normal light emission
4	Clock range change	2020 – 2039 (Year)	2001 – 2019 (Year)

Note: Settings can be changed when the power is ON, but changes are not valid until the power has been switched OFF and ON again, except in the case of switch 3 for optical level testing, which is valid immediately.

- In the case of location mode, the location estimation mode (OFF) should be used.
- In the case of reliability/TRAIM, the High-reliability/Train ON mode (SW-OFF) should be used.
- In high-reliability mode, the unit outputs the 1PPS signal only when no failed satellites are detected. In the case of two or more failed satellites, correct operation of the unit cannot be assured.
- In the case of clock range change, the switch should be OFF before 2019 and ON after 2020.

For the details, see the Appendix D.

4.2 How to Turn on the Power

Turn on the power switch. Power ON is confirmed by the illumination of the "5V" LED on the front panel of the unit.

4.3 Checking the 1PPS Signal

After the power is turned on, check that 1PPS signals are output. If 1PPS signals are not output, it is impossible to use the time signals that are output from the GPS receiver unit. Output of 1PPS signals is confirmed by the blinking of the "1PPS OUT" LED on the front panel of the unit.

5. Operation

5.1 1PPS Signal Output

The GPS receiver unit outputs 1PPS signals with each pulse defining the instant of time described by the preceding frame of serial data. (For the time signal transmission format, refer to Appendix D.)

Following power-up, the GPS receiver begins outputting 1PPS signals after the acquisition of the almanac data and the estimation of the receiver location (or the antenna location to be more exact) are completed.

Almanac data received from the satellites include satellites outline orbit information and UTC time correction parameters. It takes about 12 to 30 minutes to acquire the data.

The almanac data is backed up temporarily following power-down. If power is removed for 16 hours or more, then the data back-up may be lost and will have to be re-acquired on power-up.

If the almanac data back-up is valid on power-up, acquisition of almanac data is unnecessary.

To estimate the location, signals from four or more satellites are required in the case of normal mode; and five or more are required in the case of high-reliability mode.

Note: If the antenna is positioned in the shade of buildings, or in other locations where it is difficult to receive satellite signals, then location estimation may take a longer time or may even be impossible.

If satellites are closely aligned in relation to the receiver, then it may not be possible to achieve a location estimate, even when the necessary numbers of signals are received. The reason for this is that, as the angle between received signals becomes small, the error in location estimation becomes large.

Accordingly, installing an antenna in a location of narrow visual field such as between tall buildings may make the location estimation impossible. When using the high-reliability mode and/or TRAIM function, the alignment of satellites has even stricter limits.

The location estimation may take more than an hour depending on constellation of satellites in case of the high-reliability mode.

The location estimation is required each time the power is turned on.

After the location estimation is completed, the 1PPS signal is output in normal mode if signals from one or more satellites are received; and two or more in high-reliability mode.

The initialization time for the 1PPS signal at power-up varies as shown in Table 5.1.1, depending on the state of the almanac data back-up.

Table 5.1.1 1PPS Output Start Time

Back up of almanac data	Initial time needed for 1PPS signal output from power on
Lost	30 seconds to 1 hours (*1)
Available	10 seconds to 1 hours (*1)

(*1) It may take further time depending on constellation of satellites and antenna position.

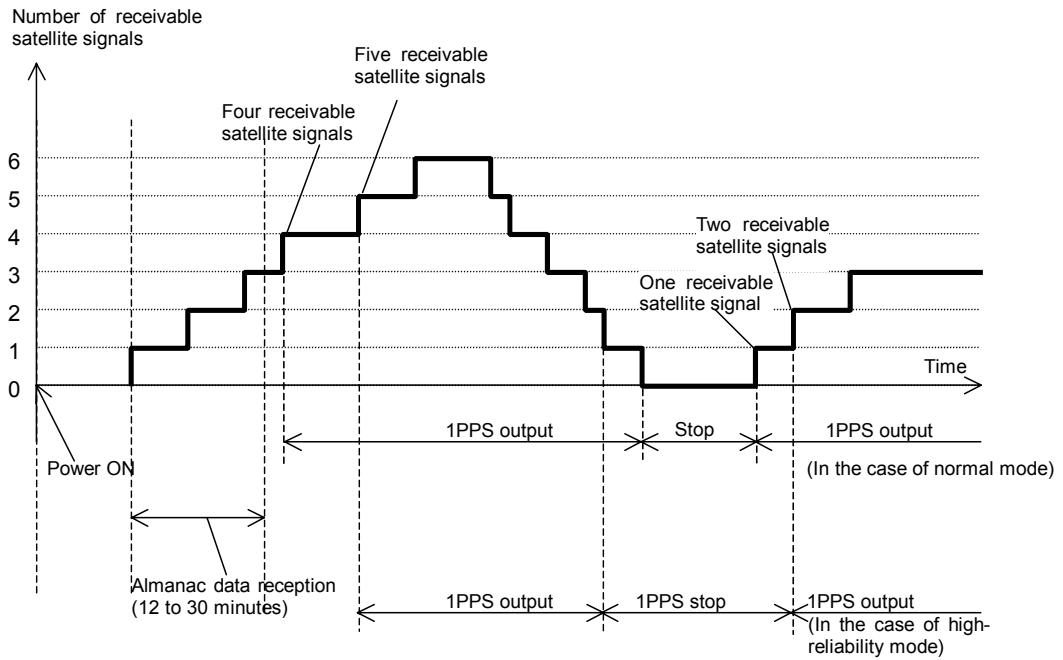

Figure 5.1.1 Receiving Satellite Signals and 1PPS Output Status

5.2 Time Data Output

On power-up, time data (serial data consisting of year-month-date and hour:minute:second) is output from the receiver's internal RTC (real time clock).

If satellite signals are received, then time data transmitted by the satellite (i.e., GPS time) is output until acquisition of the almanac data is completed. The GPS time deviates from UTC time by an accumulated number of leap seconds.

When reception of the almanac data is completed, then UTC time is output.

Any device receiving this output data can distinguish between the RTC, GPS and UTC time data, since this is indicated in the data itself.

6. Installation

6.1 Receipt of GPS Receiver Unit

When GPS receiver units are received, carry out the acceptance inspection immediately. In particular, check for damage during transportation, and if any is found, contact the vendor.

Always store the GPS receiver units in a clean, dry environment.

6.2 Installing GPS Receiver Unit

⚠ CAUTION

Do not remove flanges from the main unit, as this may cause a failure.

The flanges attached to both sides of the unit are used to fix the main unit to a rack or plain table installed in a stable location.

6.3 Installing Antenna

⚠ DANGER

A surge arrester must be installed between the antenna and the GPS receiver unit. It must be grounded according to the methods specified in section 6.4 so as to prevent injury or malfunction.

Install the antenna in the specified location in the method shown in the diagrams below.

CAUTION

An improper antenna installation location may cause malfunctions.

Locate the antenna as far as possible from other antennas. If the antenna is located within one meter from other antennas, it may not be possible to receive the GPS signal correctly.

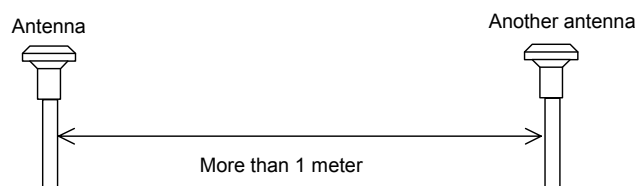

Locate over the top of fence.

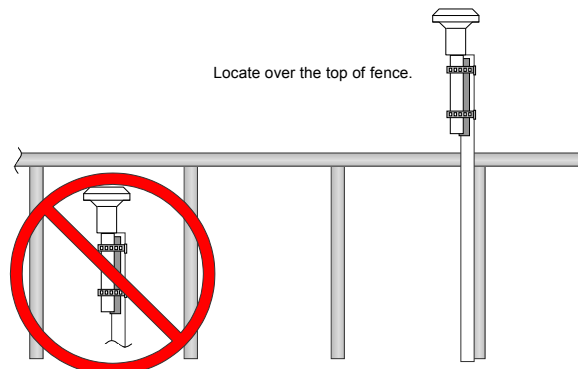

Don't locate in shade of obstructing objects (Box, antenna, etc.).

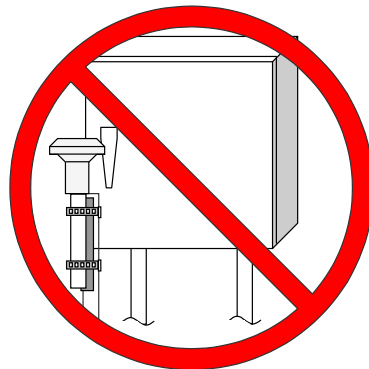

Don't locate in shade of obstructing objects (Box, antenna, etc.)

Next, connect the antenna to the arrester with a coaxial cable.

The following antennas are recommended: GPA-014B or GPA-017S manufactured by Furuno Electric Co., Ltd. The specifications for and dimensions of these antennas are described in Appendix C.

The antenna should be fixed to a support pole with Debe clamps and U bolts. An example installation of the Furuno Electric antenna, using the accompanying clamps, is shown in Figures 6.3.1, 6.3.2 and 6.3.3.

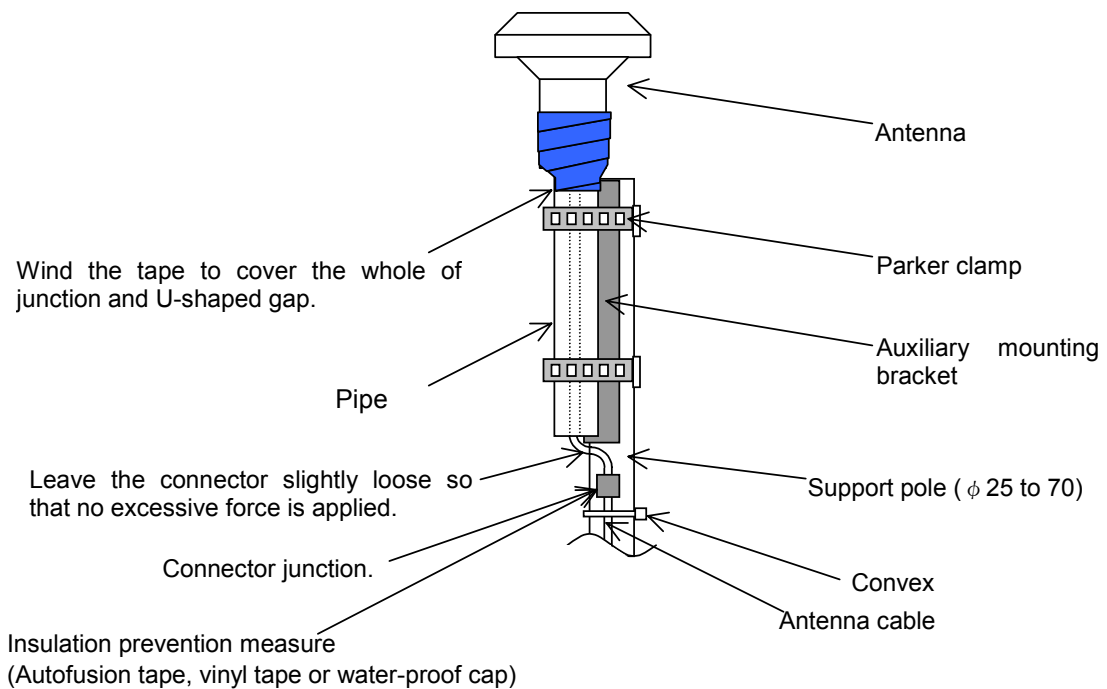

Figure 6.3.1 An Example of Installation, Using GPA-017S for Antenna

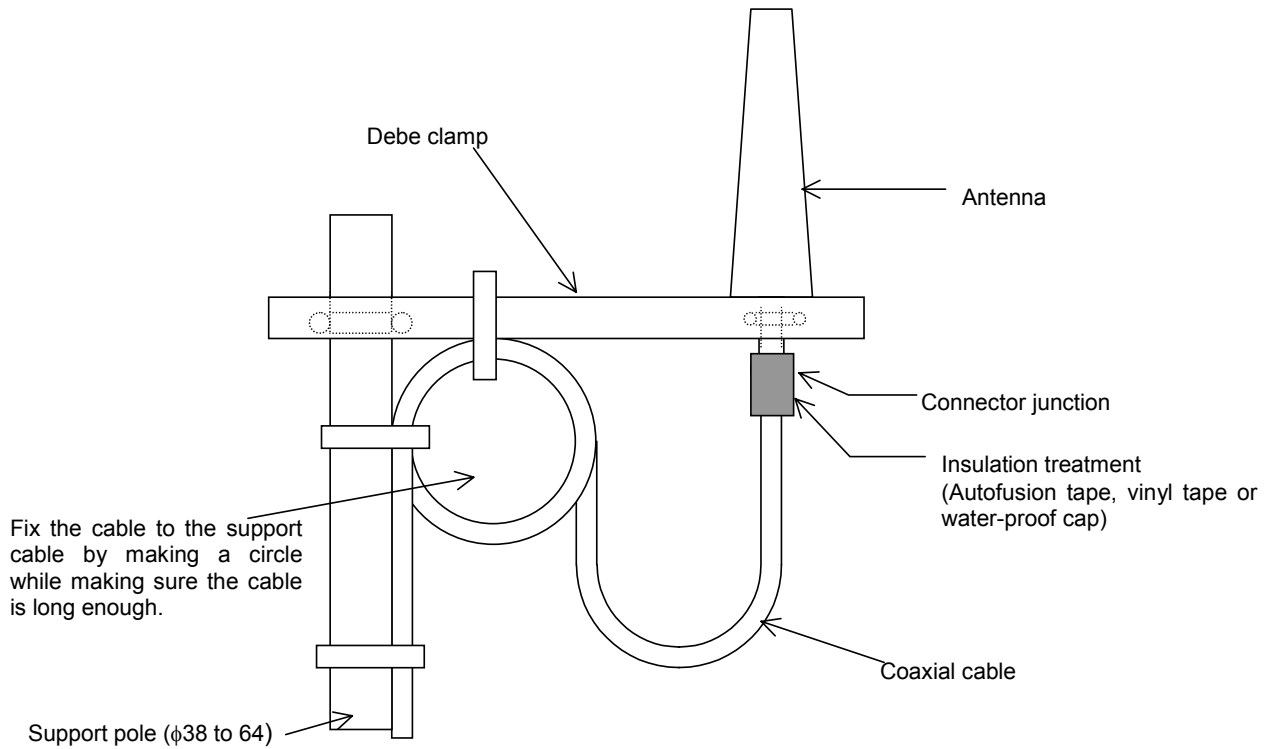

Figure 6.3.2 An Example of Installation, Using GPA-014B for Antenna (A)

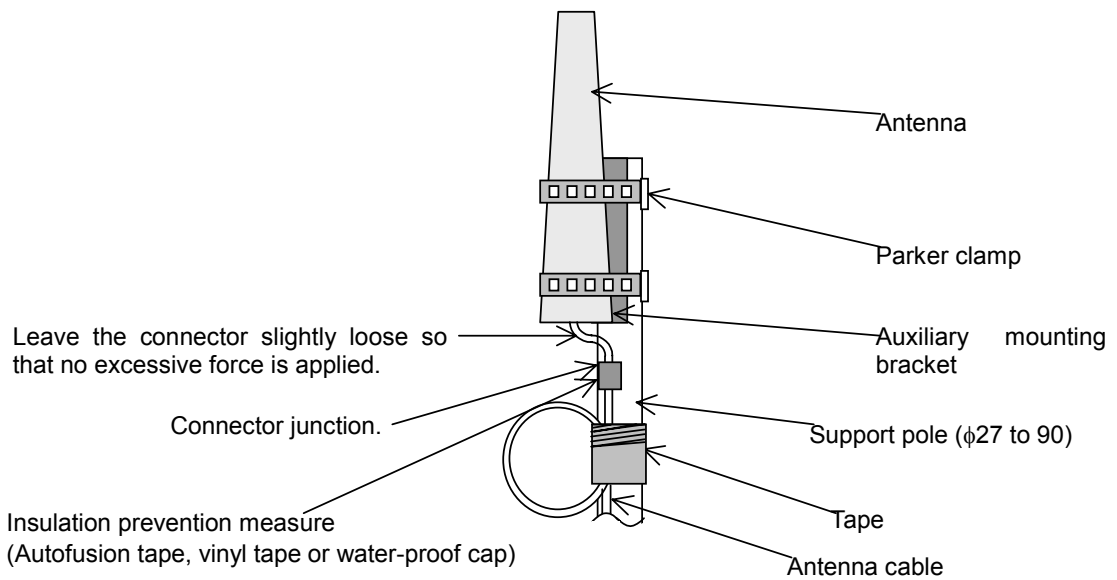

Figure 6.3.3 An Example of Installation, Using GPA-014B for Antenna (B)

6.4 Installing Surge Arrestor

The GPS antenna must be installed outdoors, so a surge arrestor is required as a measure against induced surges due to lightening. (This is not effective against a direct lightening strike.)

The arrestor should be installed at the point where the coaxial cable from the antenna enters the building. A recommended arrestor is CA-23RS made by Daiichi Denpa Kogyo. The specifications for and the appearance diagram of the arrestor are described in Appendix C. The surge arrestor is not water-proof and should be installed in a box. Connect the coaxial cable to the arrestor by an N-type connector.

Stitch or solder a copper earth wire, 2.5 to 3.2 mm in diameter, to the earthing terminal on the arrestor. Connect the other end of the wire to the arrestor's own earthing point. Make the connection distance between the arrestor and the earthing point as short as possible and protect the earth cable with an insulation pipe.

The surge arrestor must have its own direct connection to earth and must not share an earth connection with other equipment. Failure to comply with this requirement will result in risk of electric shock at time of lightening strike.

6.5 Installing Fibre Optics

For the fibre optic connection, multi-mode GI fibre (62.5/125 μm) is used. When laying fibre optic lines, ensure a minimum curvature radius of 50 mm.

▲CAUTION

Do not bend the fibre optic cable sharply, as this may damage it and may cause malfunctions. Ensure that fibre optic connectors are fixed securely.

6.6 Connecting the Power Supply and the Earthing Terminal

Connect the 48Vdc power cable and the earth cable to the terminal block with M4 crimped terminals. For safety purposes, make sure that the earth connection is reliable.

⚠CAUTION

The earthing terminal must be securely earthed. The failure to ground may cause malfunctions, electric shocks or injury.

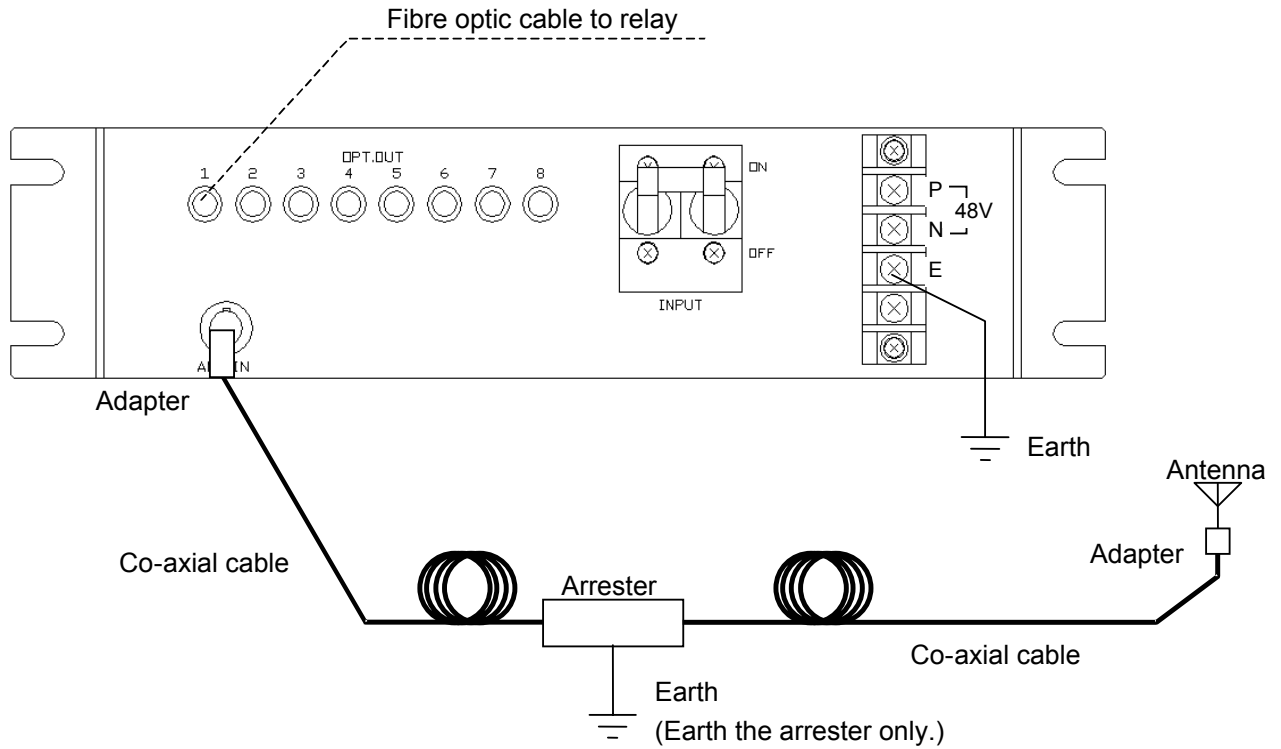

Figure 6.6.1 External Connection of GPS Receiver Unit

7. Preparation for Installation

The following issues should be considered prior to commencing installation of the system.

7.1 Selecting an Antenna and Cables

The choice of antenna and cable types should be made based on the distance from the antenna installation site to the GPS receiver unit installation site, and also on the cabling conditions.

Coaxial cables of characteristic impedance 50 ohms are required. The signal frequency is 1.57GHz.

The antennas may be selected according to the distance between the sites. In the case of areas where snow is prevalent, the use of pole-shaped antennas is advisable.

The maximum extension lengths of cables based on the combinations of antennas and cables are shown in Table 7.1.1. It shows the lengths from the antenna to the GPS receiver unit.

Table 7.1.1 Maximum Extension Lengths of Cables Based on Combinations of Antennas and Cables

	Coaxial Cable Type				
	RG213	Fujikura 5D-FB	Belden 9913	Westflex 103	Fujikura 8D-FB
GPA-017S antenna	16m	25m	35m	35m	35m
GPA-014B antenna	33m	50m	75m	75m	75m

7.2 Selecting Coaxial Cables and Conversion Adapters

N-type (NP) connectors are installed on both ends of the coaxial cables. Conversion adapters are required, since different types of connector are fitted on the antenna, surge arrestor and GPS receiver.

Required conversion adapters are as shown in Table 7.2.1.

Table 7.2.1 List of Conversion Adapters

Part	Required conversion adapter	Remark
Connector conversion from coaxial cable to antenna	NJ-BNCP adapter or NJ-TNCP conversion cable (within 1 m)	The 5D-FB and RG213 cables can be fitted with a BNC-P connector, in which case, no conversion adapter is needed for connection to the BNC-fitted antenna and GPS receiver unit.
Connector conversion from the coaxial cable to the GPS receiver unit	NJ-BNCP adapter	

7.3 Selecting an Antenna Installation Location

⚠CAUTION

If antenna is not located in the method described below, it may not be possible to receive the GPS signal correctly.

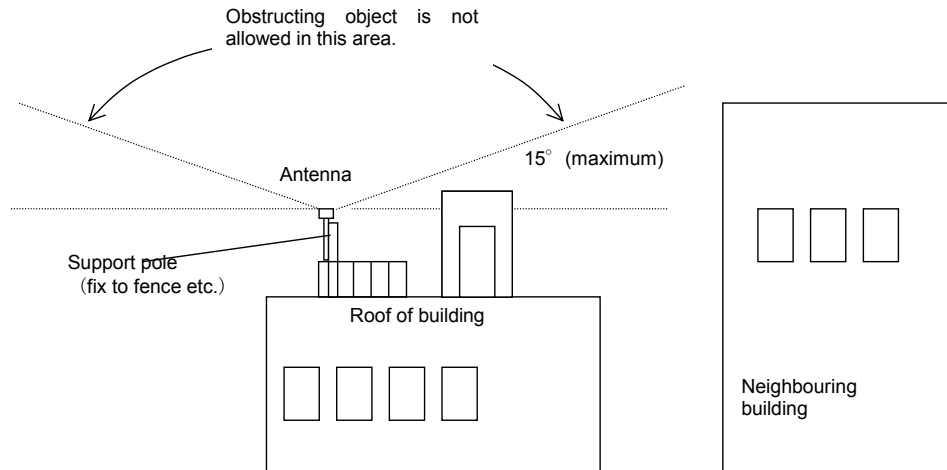

The antenna is installed outdoors to receive satellite transmissions. It should be installed in a location that offers an unobstructed view of the sky with an elevation angle of 15 degrees to horizontal. This is imperative for operation in high-reliability mode with operation of the TRAIM function, since it is necessary to received signals from satellites which are widely spaced. These restrictions can be relaxed for normal mode operation.

Since the alignment of satellites varies during the course of a day, it is necessary to test that the installation is adequate to allow immediate location estimation and continuous 1PPS output for an entire one day period.

On sites where installation conditions are not ideal then it may be necessary to conduct a survey to establish whether reception quality is adequate. This may include situations where the antenna must be mounted on a wall, or if the visual field is narrow or if the site is close to structures which reflect electromagnetic waves.

8. Maintenance

8.1 Regular Maintenance

Surge arrestors are degraded by lightening induced voltages, resulting in changes to their discharge breakdown voltage. They require periodic checks and should be replaced if necessary.

They can be checked by removing the internal components from the arrestor cabinet. The glass pipe part should be inspected and if it has turned black then replacement is required.

▲CAUTION

The surge arrestor must be periodically maintained to prevent malfunction.

8.2 Troubleshooting

In the event of failure or unexpected behaviour of the unit, the following items should be checked.

Symptom	Possible cause and / or remedy
"5V" LED is off.	Check that power connections to the unit are made correctly and that the power supply switch on the front panel is ON. If so, then a failure of the internal power supply unit is a possible cause.
"ERROR" LED is on.	The GPS receiver unit is failed. The internal circuit clock has stopped oscillating.
"1PPS OUT" LED does not start to blink after power ON.	Check the antenna location and connection. Check that the DIP switches are set to proper positions.
It takes a long time until "1PPS OUT" LED starts blinking after power ON.	In cases where the power has been turned off for 16 hours or more, internal back-up data may be lost and it may take about 30 minutes before the unit is ready to output the 1PPS signal. This case is not an error. However, if 1PPS is not output after about 30 minutes, check that the antenna is installed in a satisfactory location.
During operation, the 1PPS output is interrupted.	Check to make sure that the antenna is installed in a satisfactory location.
Data cannot be detected on the receiving device.	Check that the optical fibre is connected securely and that it is not damaged or severely bent (minimum bend radius is 50mm).
The 1PPS signal or the time data is irregular.	Possible failure of the internal receiver.
"1PPS OUT" LED does not turn on.	Check that the DIP switches are set to proper positions.

If a failure continues, stop using the GPS receiver unit and contact the vendor.

Appendix A

Outline of GPS Receiver Unit

Outline

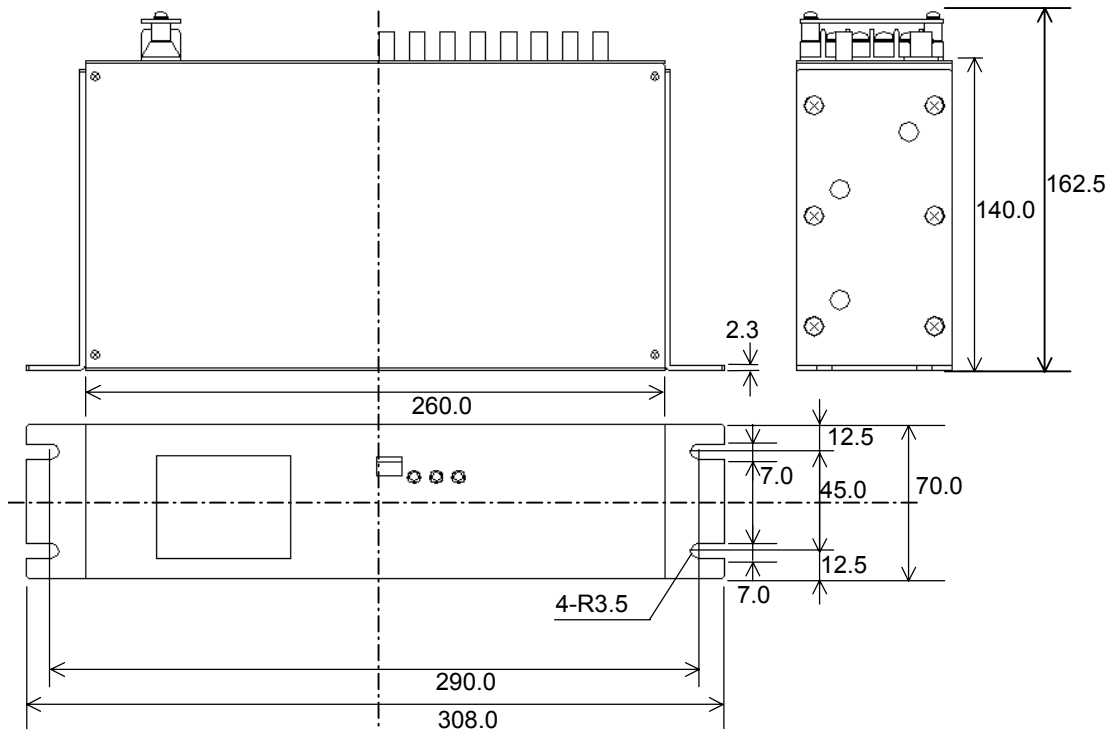

Panel cutout

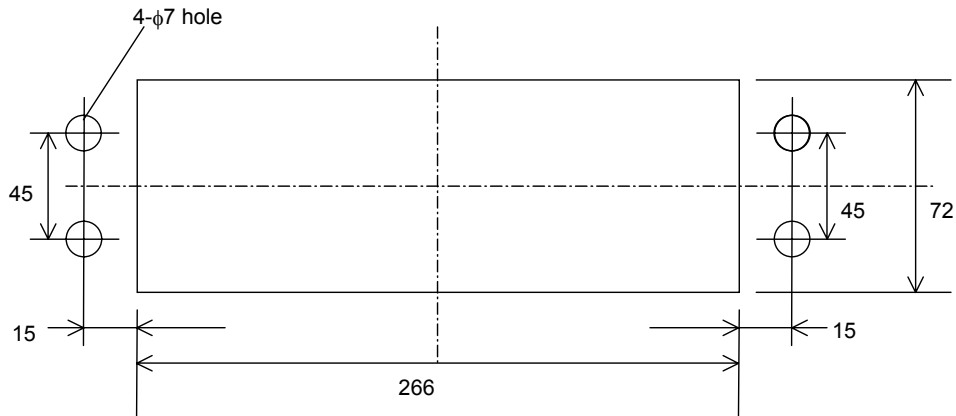

Appendix B
Technical Data

TECHNICAL DATA**Ratings**

DC power supply:	48Vdc-10W (Operative range: 38.4 to 57.6Vdc)
AC ripple on dc supply IEC 60255-11:	maximum 12%
DC supply interruption IEC 60255-11:	less than 10ms at 48Vdc
Permitted duration of dc supply voltage interruption to maintain normal operation	

Mechanical design

Weight:	2.7kg
Installation:	Flush mounting

Receiving function

Number of receiving satellites:	Eight satellites received in parallel
Receive signals:	L1 C/A code
Receive frequency:	1575.42 MHz

Time transfer accuracy

Within $\pm 2\mu\text{s}$ with respect to UTC (When the receiver is tracking GPS Satellites)

Data backup

Data life:	more than 16 hours
------------	--------------------

Communication Interface

Connection:	ST connector
Cable type:	GI multimode optical fibre (62.5/125 μm or 50/125 μm)
Wavelength:	820nm
Cable Length:	0 to 1km (3dB/km)

GPS antenna interface

Preamplifier power supply for Antenna	Min 4.5V(at 20mA), Min 4.0V(at 40mA)
Connection:	BNC connector
Cable type:	50 ohm coaxial cable

GPS antenna

NF:	Max 3dB
Gain:	10 to 35dB(Antenna + Amp + Cable)

Environmental Performance Claims for GPS Receiver

Test	Standards	Details
Atmospheric Environment		
Temperature	IEC60068-2-1/2	Operating range: -10°C to +55°C. Storage / Transit: -25°C to +70°C.
Humidity	IEC60068-2-3	56 days at 40°C and 93% relative humidity.
Mechanical Environment		
Vibration	IEC60255-21-1	Response - Class 1 Endurance - Class 1
Shock and Bump	IEC60255-21-2	Shock Response Class 1 Shock Withstand Class 1 Bump Class 1
Seismic	IEC60255-21-3	Class 1
High Voltage Environment		
Dielectric Withstand	IEC60255-5	2kVrms for 1 minute between PSU terminals and earth.
High Voltage Impulse	IEC60255-5	Three positive and three negative impulses of 5kV(peak), 1.2/50µs, 0.5J between all terminals and between PSU terminals and earth.
Electromagnetic Environment		
High Frequency Disturbance / Damped Oscillatory Wave	IEC60255-22-1 Class 3 IEC61000-4-12, EN61000-4-12 Class 3	1MHz 2.5kV applied to PSU terminals in common mode. 1MHz 1.0kV applied to PSU terminals in differential mode. 0.1MHz 2.5kV applied to PSU terminals in common mode. 0.1MHz 1.0kV applied to PSU terminals in differential mode.
Electrostatic Discharge	IEC60255-22-2 Class 4	8kV contact discharge. 15kV air discharge.
Radiated RF Electromagnetic Disturbance	IEC60255-22-3 Class 3	Field strength 10V/m for frequency sweeps of 80MHz to 1GHz and 1.7GHz to 2.2GHz. Additional spot tests at 80, 160, 450, 900 and 1890MHz.
Fast Transient Disturbance	IEC60255-22-4 Class 4	4kV, 2.5kHz, 5/50ns applied to PSU terminals in common mode.
Conducted RF Electromagnetic Disturbance	IEC60255-22-6 Class 3	10Vrms applied over frequency range 150kHz to 100MHz. Additional spot tests at 27 and 68MHz.
Conducted Disturbance over Freq. Range 15Hz to 150kHz	IEC61000-4-16, EN61000-4-16, Class 3	Varying voltages applied in common mode as follows: 15Hz to 150Hz: 10V → 1Vrms (20dB/decade) 150Hz to 1.5kHz: 1Vrms 1.5kHz to 15kHz: 1 → 10Vrms (20dB/decade) 15kHz to 150kHz: 10Vrms
Power Frequency Disturbance	IEC60255-22-7	300V 50Hz for 10s applied to PSU terminals in common mode.

Surge Immunity	IEC61000-4-5, EN61000-4-5	1.2/50 μ s surge applied to PSU terminals in common/differential modes: 2kV/1kV (peak)
Conducted and Radiated Emissions	EN55022 Class A	Conducted emissions: 0.15 to 0.50MHz: <79dB (peak) or <66dB (mean) 0.50 to 30MHz: <73dB (peak) or <60dB (mean) Radiated emissions: 30 to 230MHz: <30dB 230 to 1000MHz: <37dB
Power Frequency Magnetic Field	IEC61000-4-8, EN61000-4-8, Class 4	Field applied at 50Hz with strengths of: 30A/m continuously, 300A/m for 1 second.
Pulsed Magnetic Field	IEC61000-4-9, EN61000-4-9, Class 5	6.4/16 μ s magnetic pulses (positive and negative) applied with magnitude 1000A/m.
Damped Oscillatory Magnetic Field	IEC61000-4-10, EN61000-4-10, Class 5	Oscillation frequencies of 0.1MHz and 1MHz applied with magnitude 100A/m.
European Commission Directives		
	89/336/EEC	Compliance with the European Commission Electromagnetic Compatibility Directive is demonstrated according to generic EMC standards EN50081-2 and EN50082-2.
	73/23/EEC	Compliance with the European Commission Low Voltage Directive is demonstrated according to generic safety standards EN61010-1 and EN60950.

Appendix C

Specification of Recommended Antenna and Arrester

Recommended Antenna

Type	GPA-014B	GPA-017S
Manufacturer	FURUNO Electric Co.,Ltd.	FURUNO Electric Co.,Ltd.
Operating connector	BNC-J	TNC-J
Applicable connector	BNC-P	TNC-P
Gain	29 to 35dB	22 to 33dB
Preamplifier noise index	No more than 2.1dB	No more than 1.6dB
Supply voltage	4 to 13V	4.0 to 5.5V
Current consumption	25 to 30mA	No more than 25mA
Operating temperature	- 30 to + 80°C	- 25 to + 65°C
Storage temperature	- 40 to + 85°C	- 35 to + 75°C
Weight	Approx. 300g	Approx. 123 ± 30g

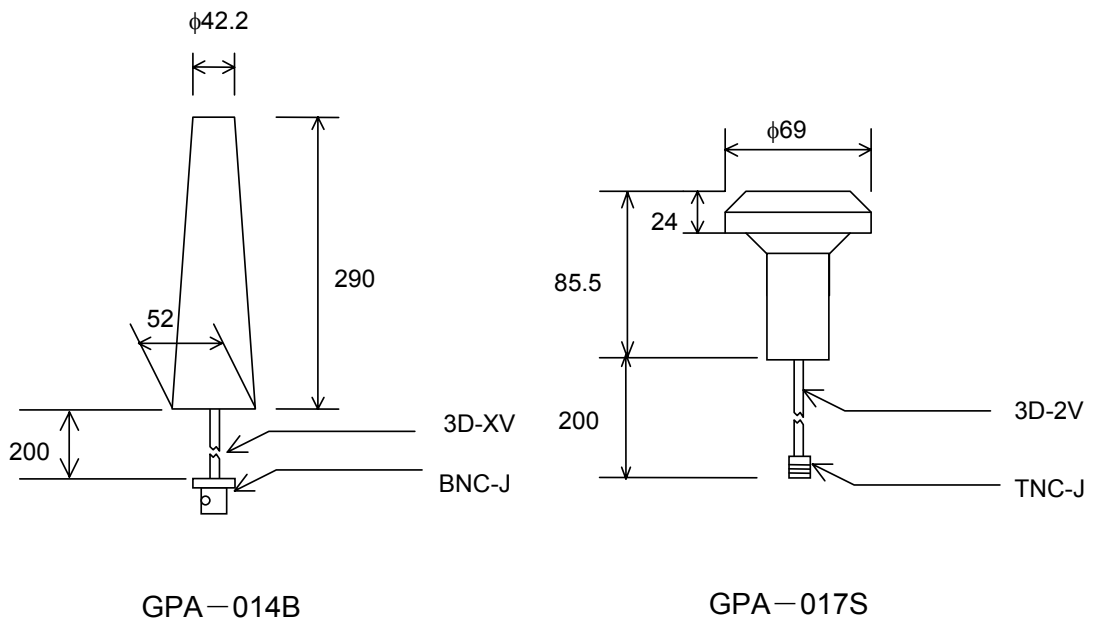

Outline of Antenna

Recommended Arrester

Type	CA-23RS
Manufacturer	DAI-ICHI DENPA KOGYO CO., LTD.
Frequency range	DC – 2500MHz
VSWR	No more than 1.1
Loss	No more than 0.2dB
Withstand power	200W PEP
Discharge breakdown voltage	DC 230V ± 15%
Impulse wave discharge voltage	1,000V
Impulse wave current endurance	6,000A
Impulse wave repetitive discharge endurance	(1 × 40) μs, 500A, at least 500 times
Insulation resistance at 100Vdc	At least 10,000M Ω
Connector	N-J / N-J
Dimensions	78(W) × 48(H) × 20(D)mm
Weight	113g

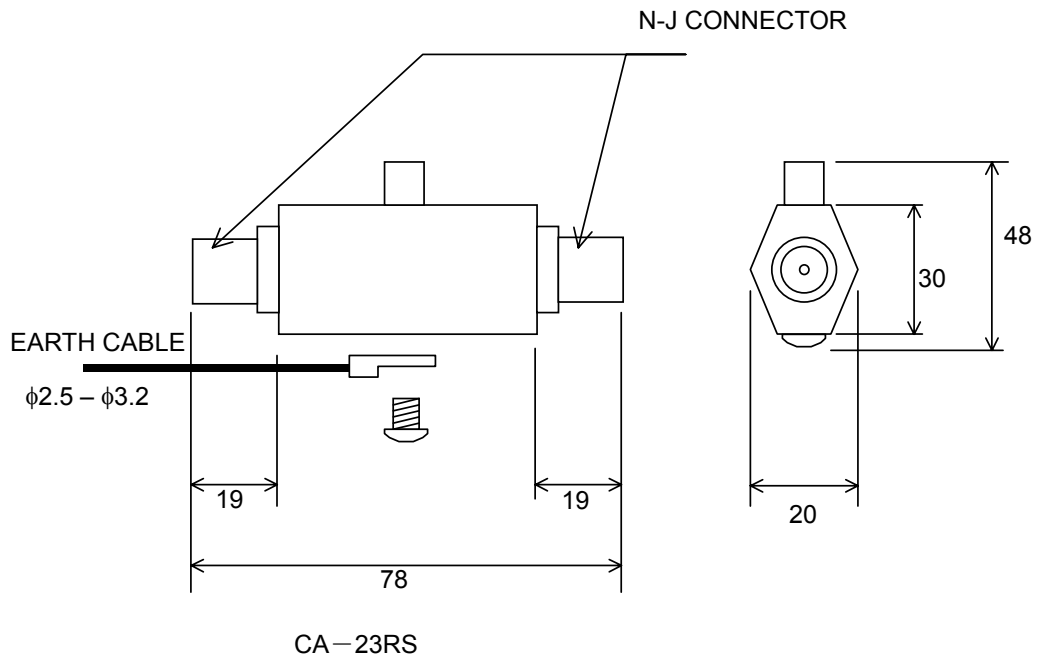

Outline of Arrester

Appendix D
Supplement

1. Time Signal Transmission Format

The time signal format is shown below, consisting of 4,800bps serial data indicating the time, and 1PPS timing signal indicating the instant of time corresponding to the serial data.

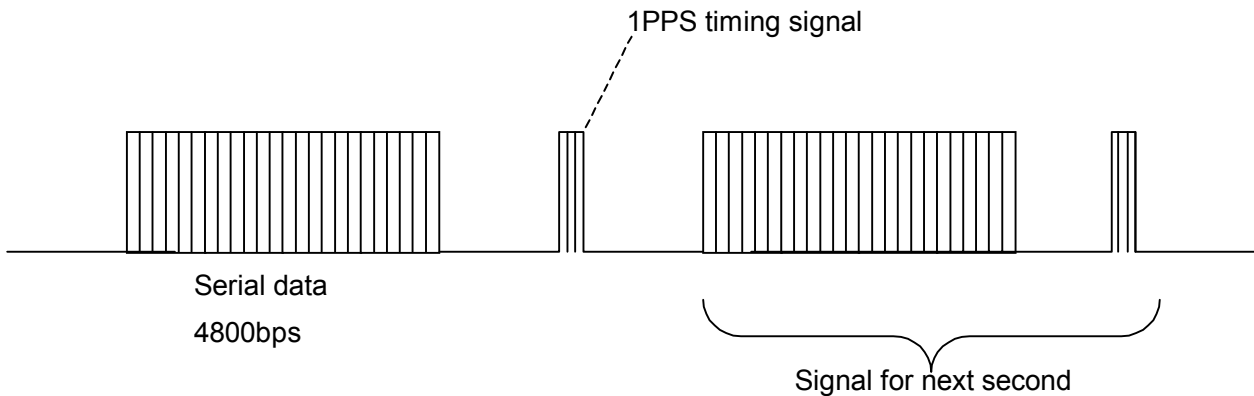

Signal code format: ASCII codes based on NMEA-0183 data
 Output data: GPtps data (time and 1PPS flag)
 GPtst data (self-test result)

2. Date Rollover

The GPS week number sent from the satellite returns to 0 (i.e., rollover) every 19.6 years; therefore, the GPS receiver unit cannot output the date data correctly. This is the rollover problem. To solve this problem, the GPS receiver unit provides a DIP switch.

- When the DIP switch 4 is set to OFF and the power is ON, the GPS receiver unit starts outputting the date and time from any date between April in 2001 and September in 2020.
- When the DIP switch 4 is set to ON and the power is ON, the GPS receiver unit starts outputting the date and time from any date between October in 2019 and March in 2039.

The default setting of the DIP switch 4 is OFF. After 2020, the DIP switch 4 should be set ON so that the GPS unit outputs the date data correctly.

Note 1: The date and time data from the GPS receiver unit are used for the recording data of GRL100 relay and do not influence the function of GRL100 relay. The 1 PPS signal is output independently of the switch 4 setting.

Note 2: For one year from October, 2019 to September, 2020, any setting of the DIP switch 4 is allowed. So, in this term, the changing of the DIP switch 4 is recommended.

3 High-reliability Mode and TRAIM Function

TRAIM (Time Receiver Autonomous Integrity Monitoring) is a function which allows the unit to detect an error in the signal from a satellite. For operation of this function, it is necessary to receive one additional signal to the minimum number normally required for output of the 1PPS

pulse. If the necessary number of satellites are available then the unit carries out error detection and removal of erroneous signals. In the event of two or more satellites in error, the operation is not assured.

In high-reliability mode, the receiver will only output the 1PPS signal when no TRAIM alarm occurs. If any satellite is in error then it must be excluded, and so two or more satellites are required for the purpose of outputting 1PPS.

Satellite alignment is subject to strict limits for operation of the TRAIM function. The antenna must be located with a wide field of view.

4. Conditions for Receiving Electric Waves from Satellites

Signals from satellites at an elevation angle of less than 5 degrees are too weak to be received.

In terms of the impact of weather, satellite signals can be received correctly while it is raining or lightly snowing, or while a small amount of snow is piled on the antenna; however, during lightening or heavy snow, the receive status may deteriorate temporarily.

Version-up Records

Version No.	Date	Revised Section	Contents
0.0	May. 23, 2001	--	First issue.
1.0	Jun. 22, 2001	3.2 5.1 6.6 7.1 Appendices	Modified Figure 3.2.1. Modified Figure 5.1.1 Modified Figure 6.6.1. Modified descriptions in Section 7.1. Modified Appendices B, C, I and K.
1.1	Jul. 19, 2001	-- 4.1 Appendix D	Corrected Type of GPS unit. (HHGP3 →HHGP1) Modified descriptions in Section 4.1. Modified descriptions Of "2. Date rollover" in Appendix D.
1.2	Jul. 25, 2001	6.3	Corrected Type of GPS antenna. (GPA-01T→GPA-016, GPA-14B→GPA-016B)
1.3	Sep. 10, 2001	3.1 3.2 4 5.1 6.6 8.2 Appendices	Modified Figure 3.1.1. Modified Figure 3.2.1. Modified descriptions in Chapter 4 and Section 4.1. Modified descriptions in Section 5.1. Modified Figure 6.6.1. Modified descriptions in Section 8.2. Modified Appendices A, B, C and D.
1.4	Jul. 30, 2002	Appendix B	Modified the description in Conducted and Radiated Emissions.
1.5	Mar. 28, 2003	6.3 7.1 Appendix C	Changed Type of GPS antenna and Figure 6.3.1. (GPA-016→GPA-017S) Added Figure 6.3.3. Modified Table 7.1.1. Changed specification and outline of antenna. (GPA-016→GPA-017S)
1.6	May.30, 2003	4.1 6.3 7.3	Added the description in Note of Table 4.1. Added the description in Caution. Added Caution.

TOSHIBA CORPORATION
